

NOTES:

1. WATERMAIN TO BE 150/100mm DIA. PVC-A TO BS PAS27 (MIN. 10 BAR) EXCEPT UNDER ROADWAYS WHERE DUCTILE IRON IS TO BE USED.
2. AT 90 DEG. TURNS USE 2 No. 45 DEG. BENDS.
3. MINIMUM COVER TO WATERMAIN TO BE 900mm.
4. SPIGOT SOCKET CONNECTIONS TO BE USED AT PVC-A/DUCTILE IRON JUNCTIONS.
5. ANCHOR BLOCKS TO BE POSITIONED AT DEAD ENDS, TEES, BENDS AT EACH SIDE OF HYDRANTS AND VALVES.
6. HYDRANT OUTLET TO BE 200mm BELOW GROUND LEVEL UNLESS REQUESTED OTHERWISE.
7. HYDRANTS SHALL BE MANUFACTURED IN ACCORDANCE WITH BS 750: 2008 TYPE 2 AND SHALL INCORPORATE A SCREWDOWN VALVE, UNDERGROUND "GUIDE IN LOAD" TYPE WITH BAYONET LEG OUTLETS AND FINE SPINDLE CAP OF CAST IRON AND IRON CHAN. HYDRANT VALVE SHALL BE "ANTI CLOCKWISE OPENING".
8. SLUICE VALVES SHALL COMPLY WITH THE REQUIREMENT OF BS5163. THEY SHALL "CLOSE BY TURNING ANTI CLOCKWISE".
9. VALVES AND HYDRANTS WHEN INSTALLED SHALL BE COVERED WITH APPROVED HEAVY DUTY METAL SURFACE COVERS. THESE COVERS MUST CONFORM WITH THE LOCAL AUTHORITY SPECIFICATIONS. COVERS TO BE HEAVY DUTY METAL COVERS TO IS EN 124.
10. INDICATOR PLATES SHALL CLEARLY IDENTIFY HYDRANT, AIR VALVE AND SLUICE VALVE LOCATIONS AND BASE BOARD LOCATIONS SHALL BE APPROVED BY THE LOCAL AUTHORITY. FIXED LETTERINGS SHALL COMPLY WITH BS3251. BACKGROUND COLOUR YELLOW TEXT COLOUR BLACK.
11. DRAINAGE MUST BE PROVIDED TO ENSURE THAT THE CHAMBERS CANNOT BE FLOODED WITH SURFACE OR GROUND WATER.
12. ALL SERVICE PIPES, CONNECTIONS AND WATER CONTROL UNITS SHALL BE AS PER OVERSEEING LOCAL AUTHORITY REQUIREMENTS.
13. ALL WATERMANS SHALL BE TESTED IN ACCORDANCE WITH SPECIFICATION & LOCAL OVERSEEING AUTHORITIES GUIDELINES FOR DRINKING WATER SUPPLY.
14. CONNECTION TO EXISTING WATERMAIN TO BE CO-ORDINATED WITH LOCAL OVERSEEING AUTHORITY.
15. CONTRACTOR TO LIASE WITH LOCAL OVERSEEING AUTHORITY FOR TESTING CLEANSING AND STERILISATION OF NEW WATERMANS.

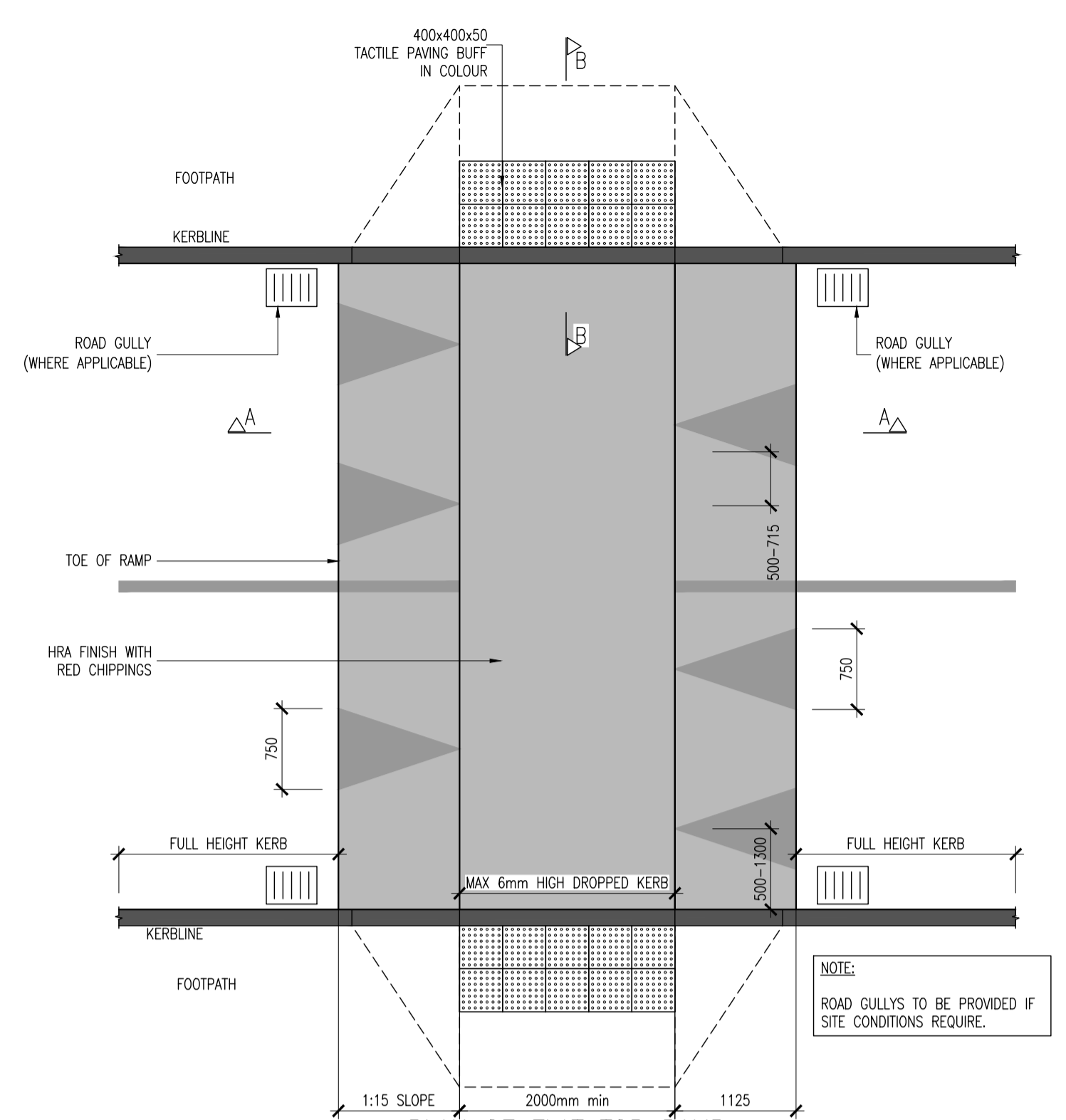

PLAN OF FLAT TOP RAMP
SCALE 1:50

NOTE:
ROAD GULLIES TO BE PROVIDED IF SITE CONDITIONS REQUIRE.

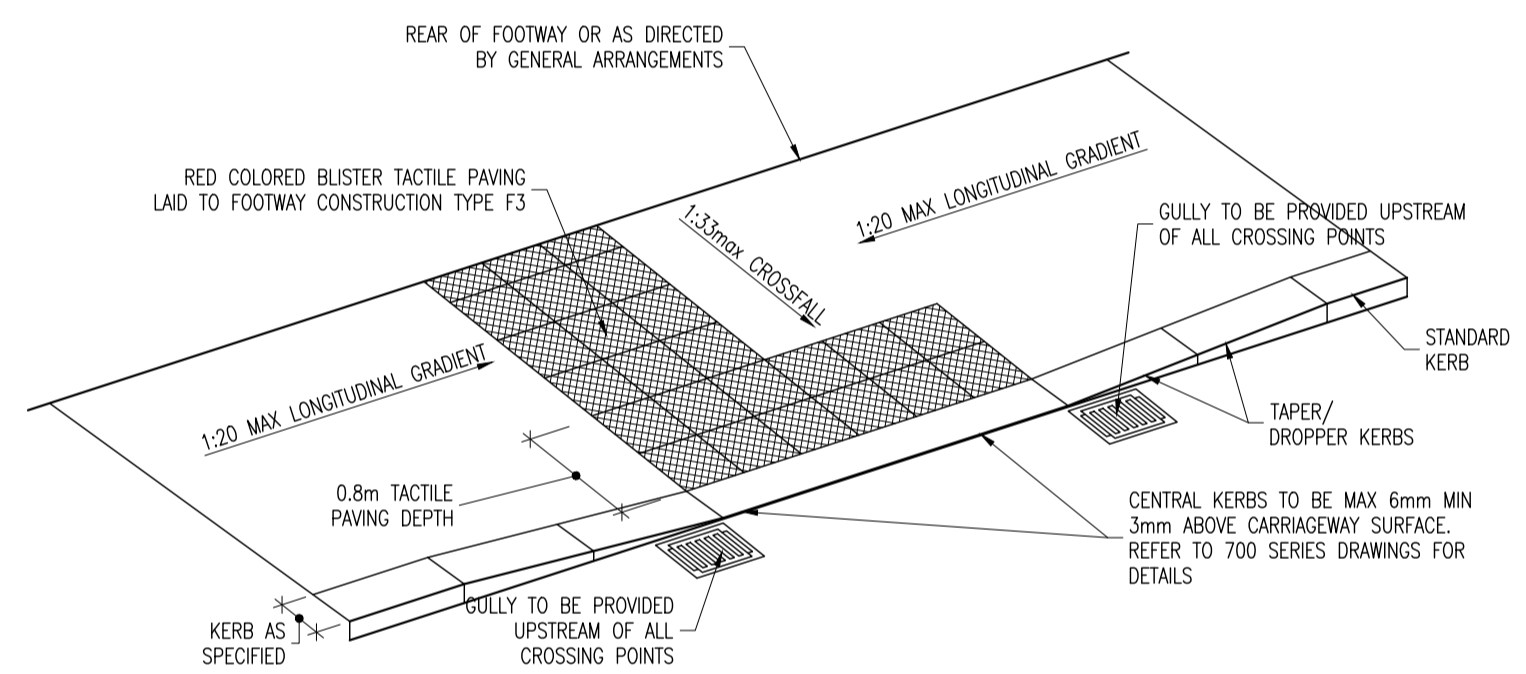

CONTROLLED DISHED
CROSSING WITH TACTILE PAVING
SCALE 1:50

DETAIL SPECIFIC NOTE:
1. CONTRACTOR TO SUPPLY CUTTING PLAN FOR INDIVIDUAL CROSSINGS FOR AGREEMENT WITH EMPLOYERS REPRESENTATIVE 5 DAYS IN ADVANCE OF WORKS

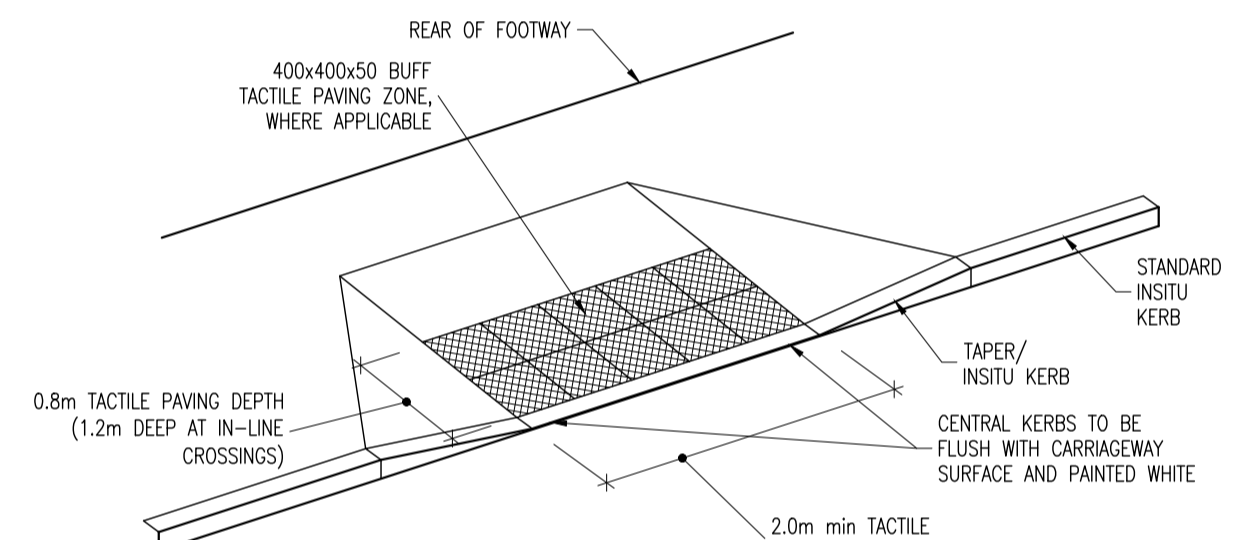

UNCONTROLLED DISHED
CROSSING WITH TACTILE PAVING
SCALE 1:50

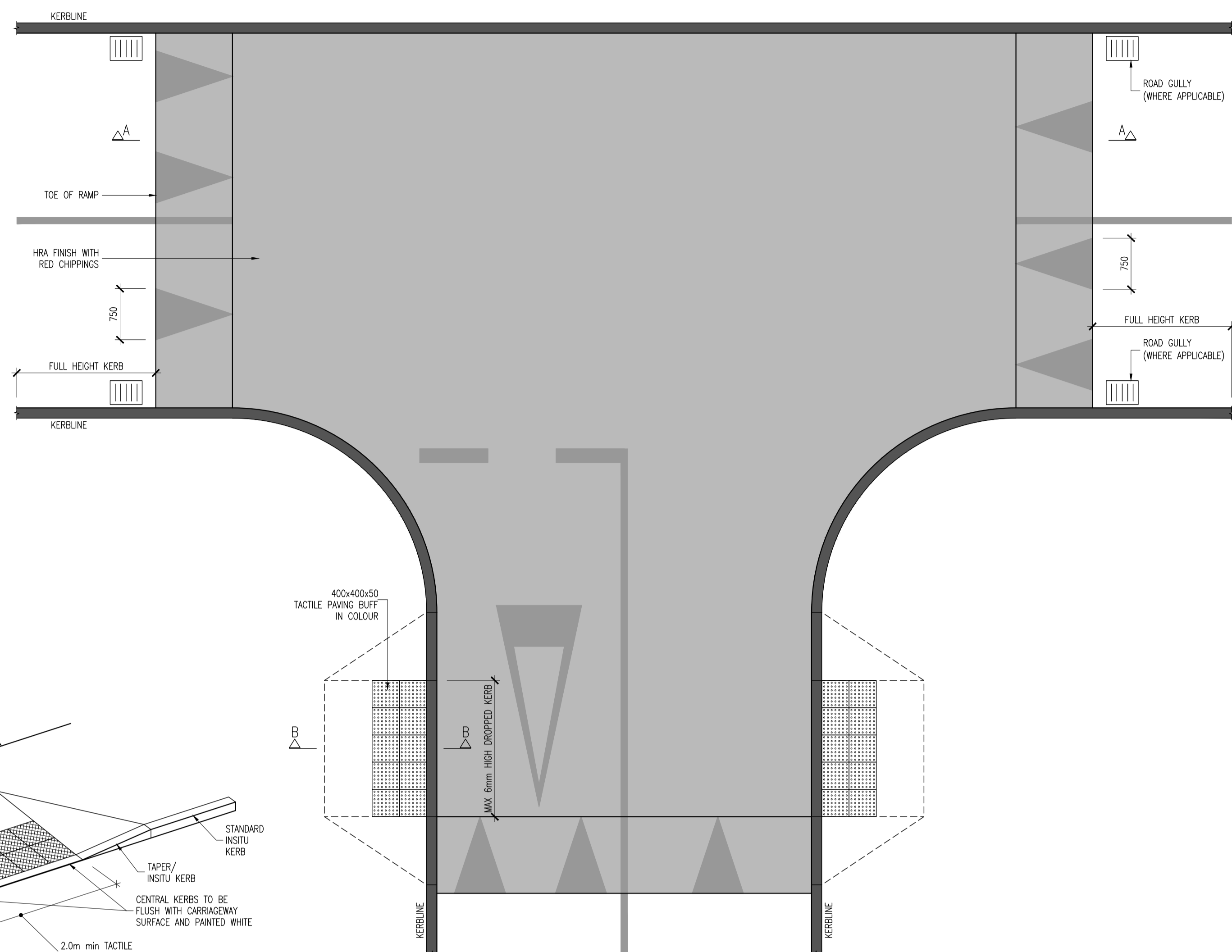

ORDNANCE SURVEY IRELAND LICENCE
No EN 0017922
© ORDNANCE SURVEY IRELAND
GOVERNMENT OF IRELAND

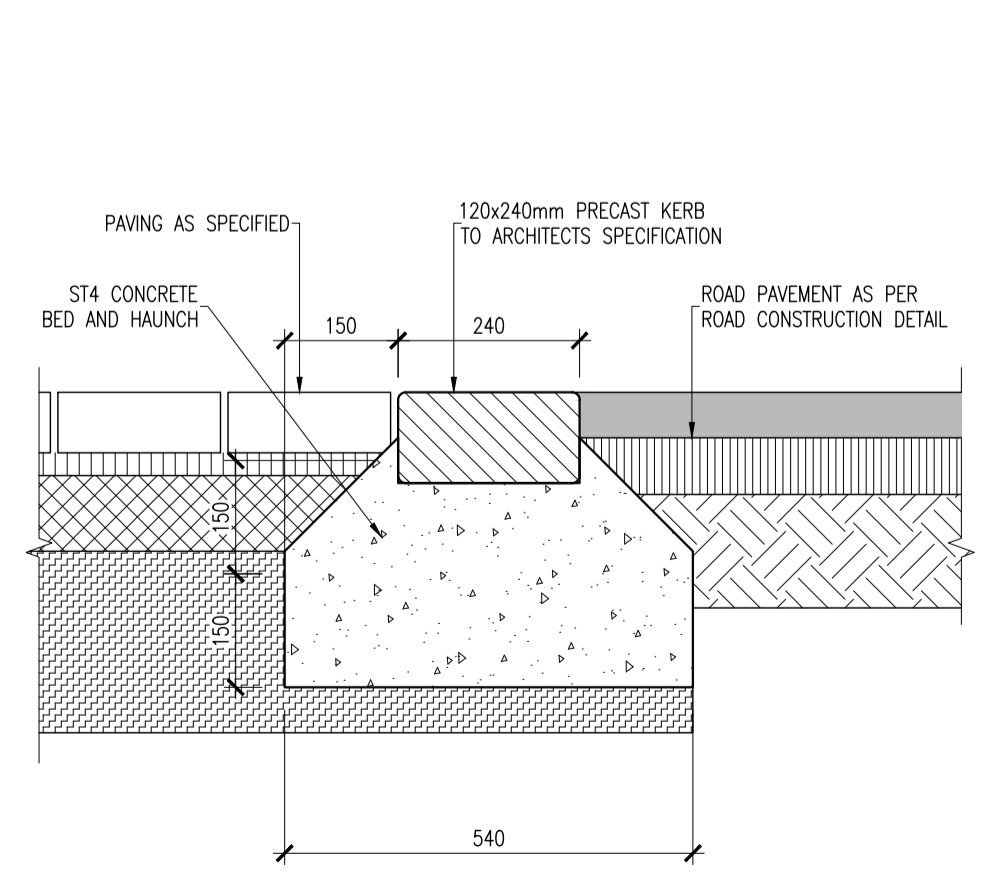

HAUNCHED SOLDIER COURSE EDGE RESTRAINT DETAIL
(DBM TO PAVING BLOCK)
SCALE 1:10

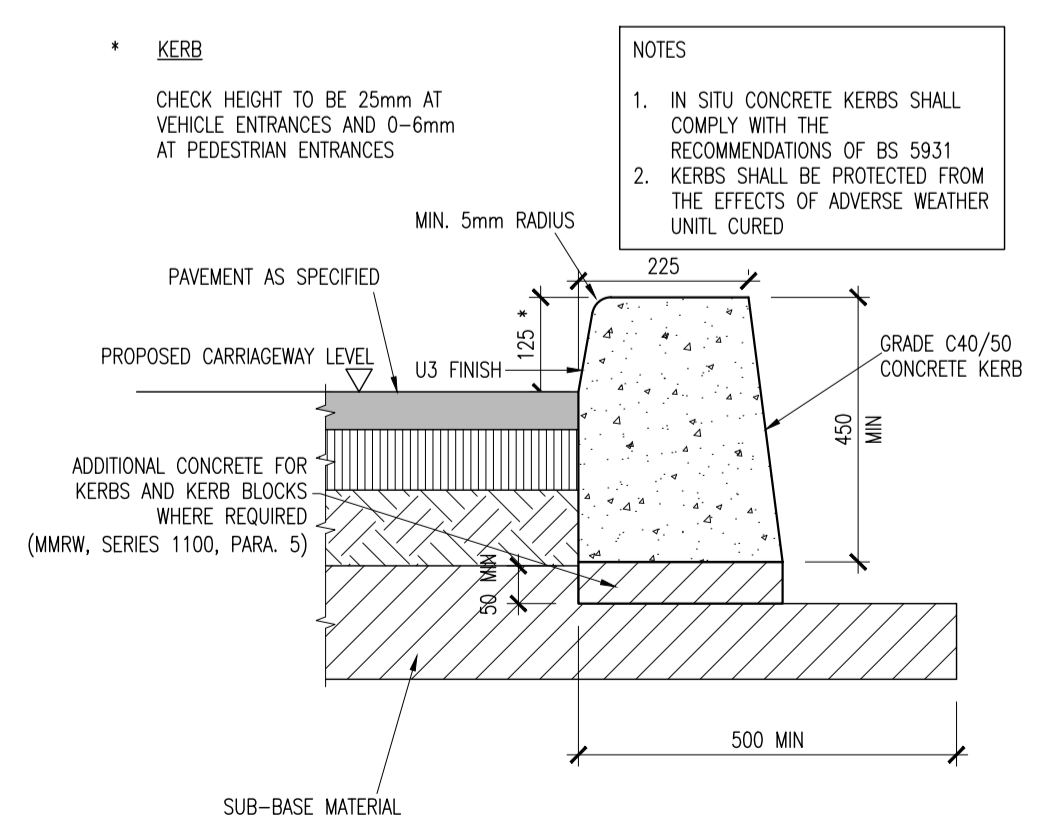

INSITU CONCRETE KERB DETAIL
SCALE 1:10

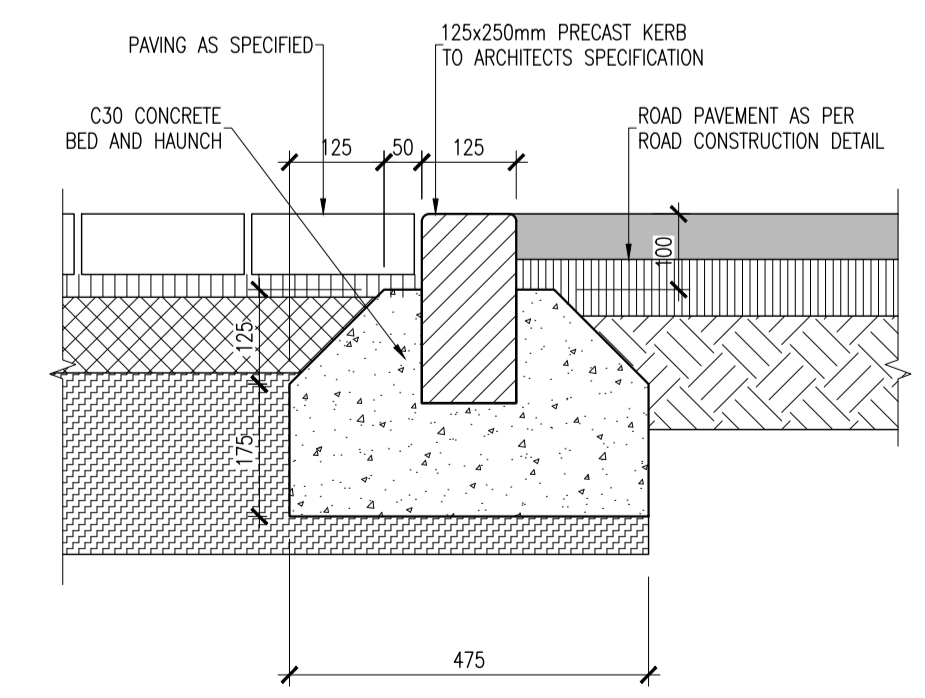

EDGE KERB DETAIL (DBM TO PAVING BLOCK)
SCALE 1:10

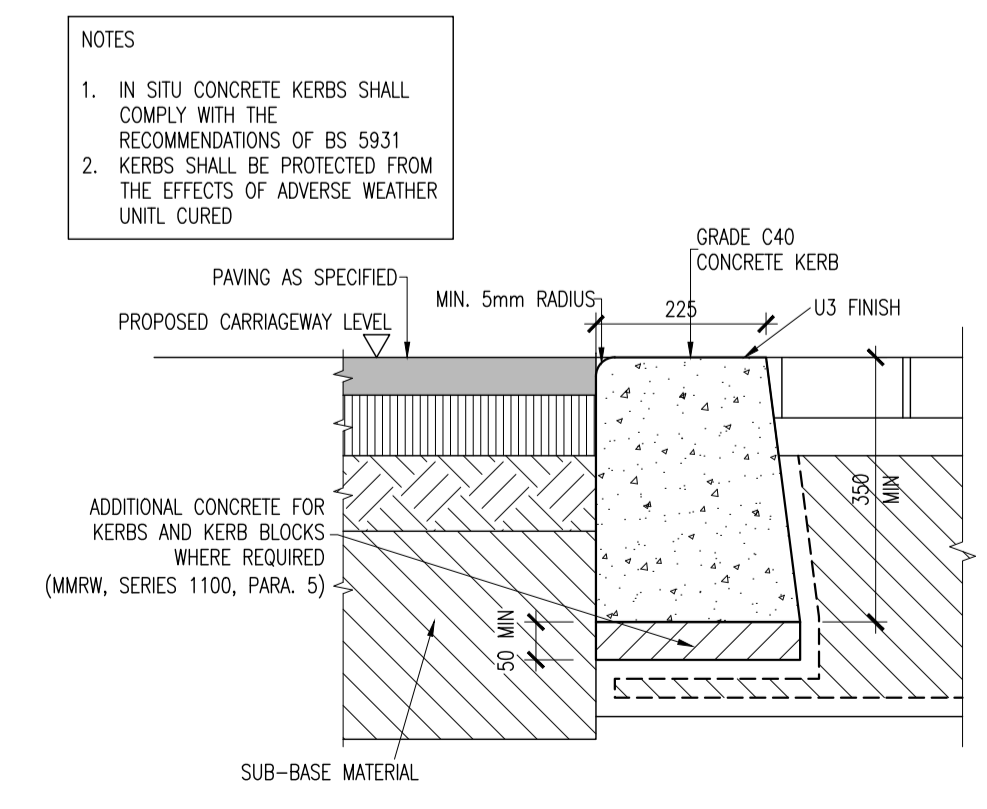

FLUSH KERB DETAIL
SCALE 1:10

rev	date	description	DKE	NOH
P01	09-06-22	PLANNING SUBMISSION		
		A - Approved		chkd.
		B - Approved with comments		
		C - Do not use		

S4 - STAGE APPROVAL PLANNING
DBFL Consulting Engineers
Civil, Structural & Transportation Engineering
www.dbfl.ie

DUBLIN OFFICE: Ormond House, Upper Ormond Quay, Dublin 7, D07 W704
PHONE +353 (0)1 400 4000
CORK OFFICE: Phoenix House, Monahan Road, Cork, T12 H1KX
PHONE +353 (0)21 2024538
WATERFORD OFFICE: Suite 10 The Atrium, Martinstown, Waterford, X91 W028
PHONE +353 (0)51 309 500

project ref.
BALLYOULSTER KDA SHD - PHASE 1
RESIDENTIAL DEVELOPMENT

drawing title
ROAD TYPICAL CONSTRUCTION
DETAILS SHEET 1

client
KIERAN CURTIN, RECEIVER OVER
CERTAIN ASSETS OF MAPLEWOOD
DEVELOPMENTS UNLIMITED COMPANY

designed by	author	scale	sheet size
GIS	RMC	AS SHOWN	A1
drawing no.	revision		
180221-DBFL-RD-SP-DR-C-5001	P01		